



Technical Information

DB4-EAGLE

XMC Module

USB 3.0 SuperSpeed Controller

Document No. 6527 • Ed. 6 • 5 April 2012

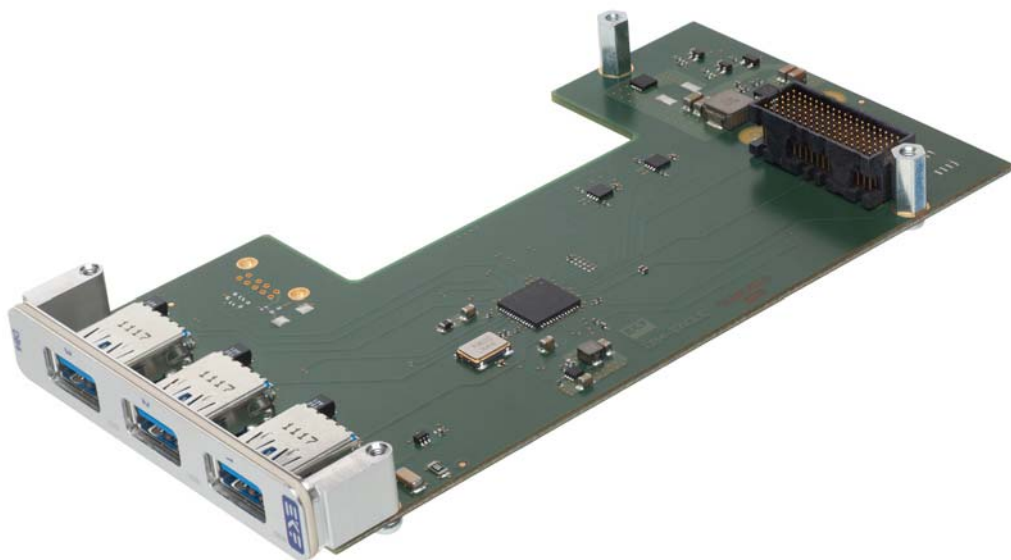

Contents

About this Manual	3
Edition History	3
Related Documents	4
Nomenclature	4
Trade Marks	4
Legal Disclaimer - Liability Exclusion	4
Standards	5
Feature Summary	6
Short Description	7
Theory of Operation	8
Block Diagram	9
Top View	10
Bottom View	11
Front Bezel	12
Installing and Replacing Components	13
Before You Begin	13
Warnings	13
Caution	13
Installing the Board Assembly	14
Removing the Board Assembly	15
EMC Recommendations	16
Technical Reference - Connectors	17
USB 3.0 Connectors	17
P15 Mezzanine Connector	20
Drivers	22
Schematics	22

About this Manual

This manual is a short form description of the technical aspects of the DB4-EAGLE, required for installation and system integration. It is intended for the advanced user only.

Edition History

Ed.	Contents/Changes	Author	Date
1	Technical Information DB4-EAGLE, english, preliminary edition Text #6527, File: db4_ti.wpd	jj	12 October 2011
2	Added photos	jj	6 February 2012
3	Added photos showing internal USB connector	jj	29 March 2012
4	Added photo showing DB4-EAGLE on a SK2-SESSION carrier card	jj	30 March 2012
5	Added photos SK2-SESSION	jj	4 April 2012
6	Added photo SK2-SESSION w. DB4-EAGLE exploded view	jj	5 April 2012



DB4-EAGLE

Related Documents

Related Information	
DB4-EAGLE Home	www.ekf.com/d/dusb/db4/db4.html
CCK-MARIMBA XMC Carrier Side Board	www.ekf.com/c/ccpu/cck/cck_tie.pdf
SK2-SESSION CompactPCI® Serial XMC Carrier Card	www.ekf.com/s/serial.html

Nomenclature

Signal names used herein with an attached '#' designate active low lines.

Trade Marks

Some terms used herein are property of their respective owners, e.g.

- ▶ CompactPCI, CompactPCI PlusIO, CompactPCI Serial: ® PICMG
- ▶ Windows: ® Microsoft
- ▶ EKF, ekf system: ® EKF

EKF does not claim this list to be complete.

Legal Disclaimer - Liability Exclusion

This document has been edited as carefully as possible. We apologize for any potential mistake. Information provided herein is designated exclusively to the proficient user (system integrator, engineer). EKF can accept no responsibility for any damage caused by the use of this manual.

Standards

Reference Documents		
Term	Document	Origin
CompactPCI®	CompactPCI Specification, PICMG® 2.0 R3.0, Oct. 1, 1999	www.picmg.org
CompactPCI® PlusIO	CompactPCI PlusIO Specification, PICMG® 2.30 R1.0, November 11, 2009	www.picmg.org
CompactPCI® Serial	CompactPCI Serial Specification, PICMG® CPCI-S.0 R1.0, March 2, 2011	www.picmg.org
PCI Express®	PCI Express® Base Specification 3.0	www.pcisig.com
PCI Local Bus	PCI 2.2/2.3/3.0 Standards PCI SIG	www.pcisig.com
USB	Universal Serial Bus Specification 3.0 & 2.0	www.usb.org
xHCI	eXtensible Host Controller Interface for Universal Serial Bus (xHCI) Rev. 1.0 2010-05-21	www.intel.com
XMC	ANSI/VITA 42.0 & 42.3, IEEE P1386.1 / Draft 2.4 & Draft 2.4a	www.vita.com



Technical Features

Feature Summary

Feature Summary

- ▶ Form factor XMC single-width mezzanine card 139mm x 74mm
- ▶ Stack height 10mm XMC to host
- ▶ Host I/F Connector P15 XMC - PCI Express, single lane, single link
- ▶ VPWR either +5V or +12V self-adjusting

- ▶ PCIe to quad-port USB 3.0 controller
- ▶ PCIe x1 Gen2 interface for optimum performance
- ▶ USB 3.0 xHCI (eXtensible host controller interface) SuperSpeed
- ▶ USB 2.0 high-speed, full-speed, low-speed supported
- ▶ Three front bezel USB 3.0 type A receptacles for attachment of external devices
- ▶ Option on-board USB 3.0 connector for system internal cabling

- ▶ Long Term Availability
- ▶ Coating, Sealing, Underfilling on Request
- ▶ RoHS compliant 2002/95/EC
- ▶ Operating temperature: 0°C to +70°C (industrial temperature range on request)
- ▶ Storage temperature: -40°C to +85°C, max. gradient 5°C/min
- ▶ Humidity 5% ... 95% RH non condensing
- ▶ Altitude -300m ... +3000m
- ▶ Shock 15g 0.33ms, 6g 6ms
- ▶ Vibration 1g 5-2000Hz
- ▶ MTBF tbd
- ▶ EC Regulations EN55022, EN55024, EN60950-1 (UL60950-1/IEC60950-1)



Short Description

The DB4-EAGLE is a XMC standard single-width mezzanine card, equipped with a PCI Express® to USB 3.0 quad-port controller. Three USB 3.0 receptacles are available from the front bezel for attachment of external USB 2.0 and USB 3.0 compliant devices. As an option, an additional USB 3.0 connector can be populated on-board, for system-internal usage.

The USB controller supports all USB data transfer protocols on any connector, SuperSpeed (USB 3.0 xHCI) as well as high-speed, full-speed, and low-speed. Since the DB4-EAGLE requires only a single PCI Express® lane (Gen2 for optimum performance), the module can be combined with any XMC carrier card.

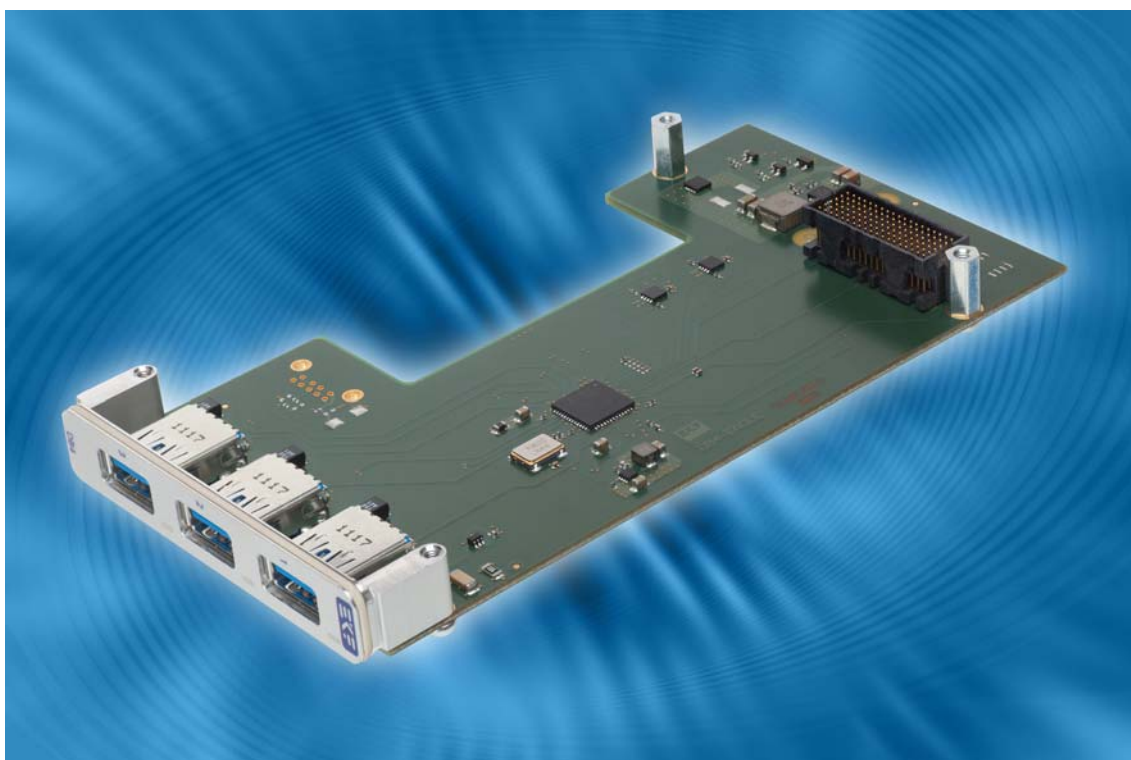

DB4-EAGLE

Theory of Operation

The DB4-EAGLE is equipped with the TI TUSB7340 single chip PCI Express® to USB 3.0 bridge. The xHCI (SuperSpeed) compliant host controller supports up to four downstream ports. Each downstream port may be independently enabled and has individual power control and overcurrent detection.

SuperSpeed USB 3.0 offers ten times the data speed of USB 2.0 (5 Gbit/s compared to 480 Mbit/s). The bandwidth of the xHCI controller is shared over all TUSB7340 downstream ports. Texas Instruments provides xHCI compliant Windows® drivers for download at www.ti.com/product/tusb7340#toolssoftware.

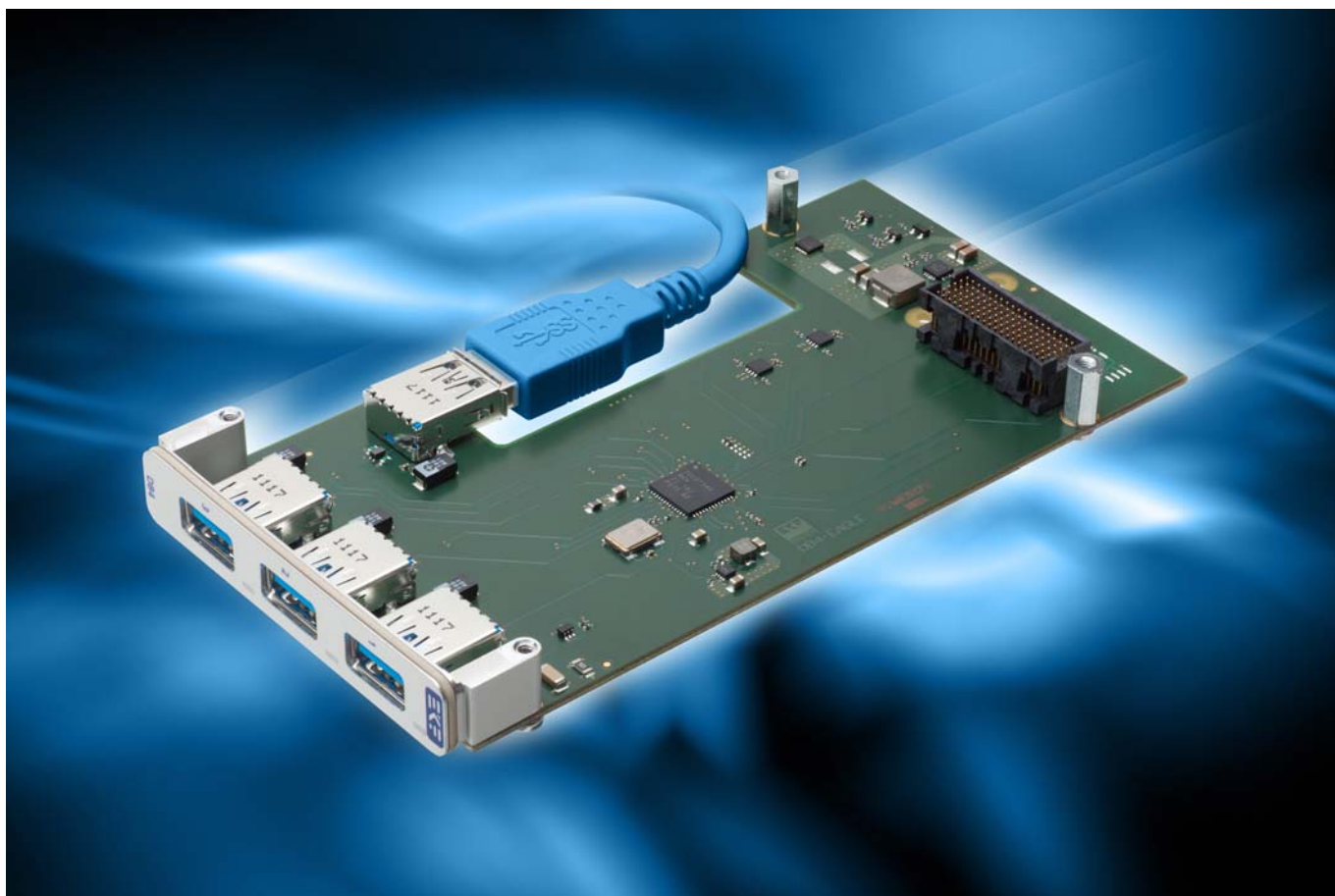

DB4-EAGLE w. Internal USB Connector

Block Diagram

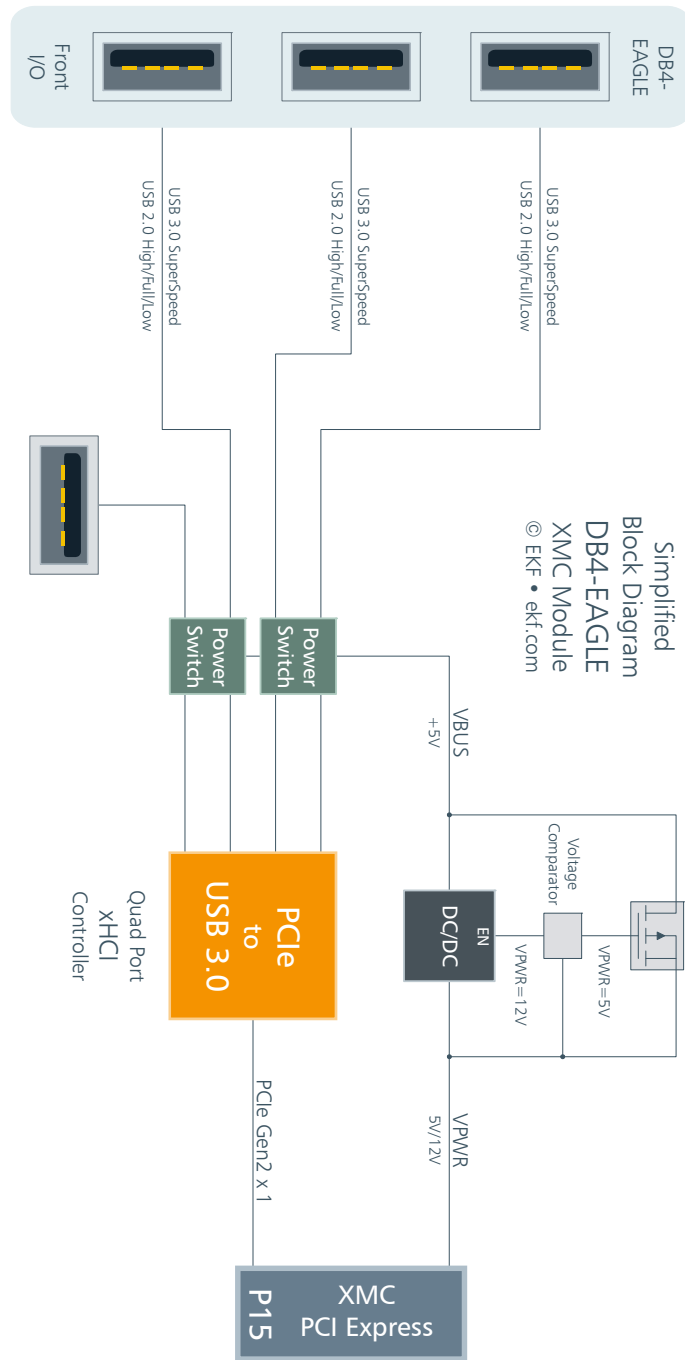

Top View

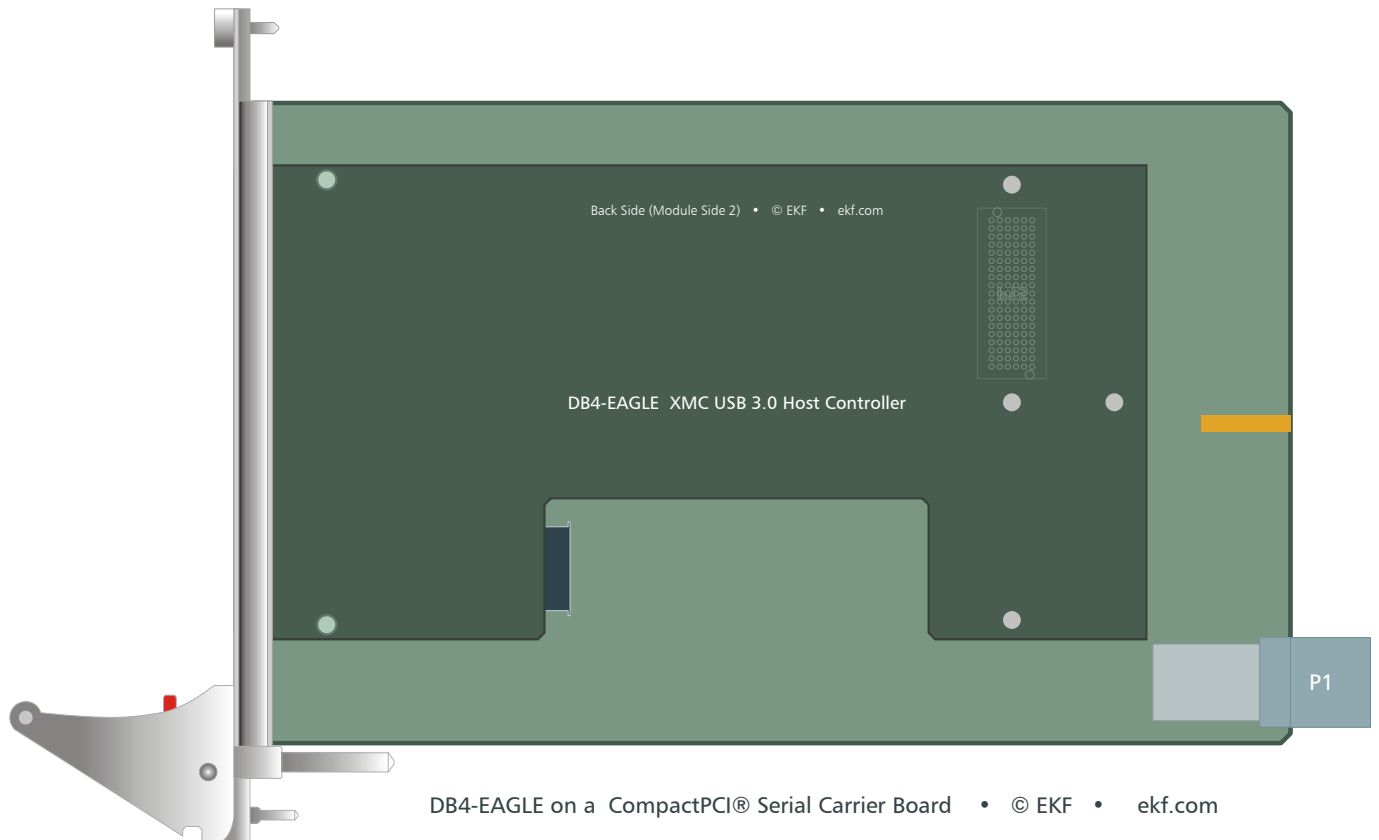

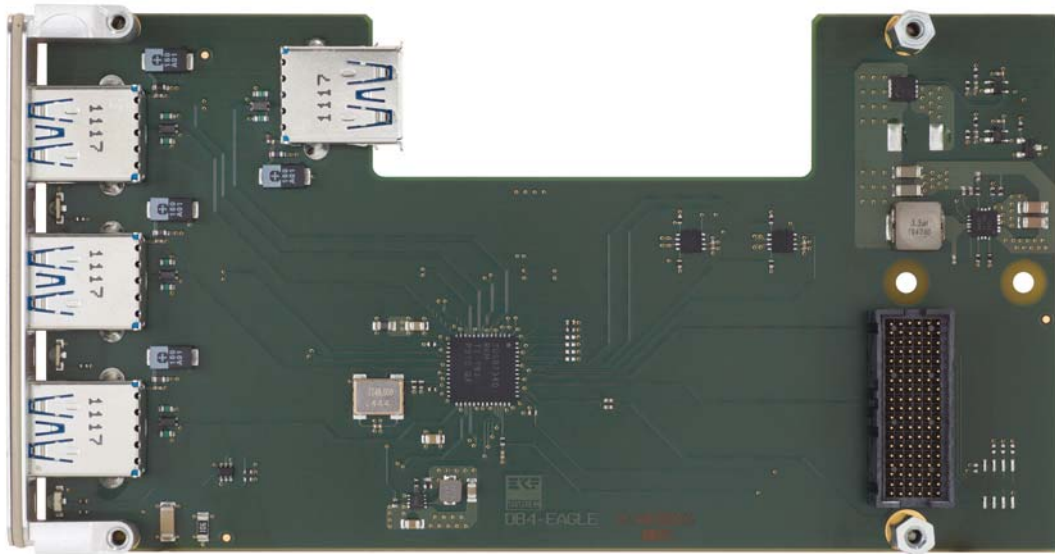

Bottom View

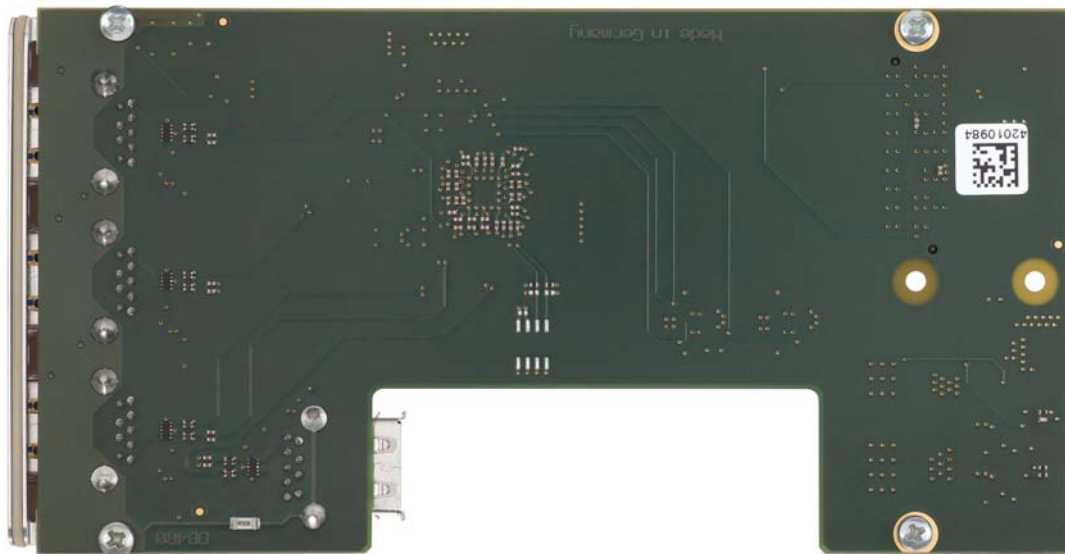

Front Bezel



LEDs (green) are provided as USB VBUS (+5V) indicator, associated to the particular receptacles. The upper bicolour LED is in addition assigned to the optional internal USB connector (yellow). Since VBUS is controlled by the USB driver software, the LEDs are lit when a connector is ready for use. Vice versa, a LED is off if the respective USB port is not initialized, intentionally switched off, or a short-circuit situation is detected, presented by the connected device.

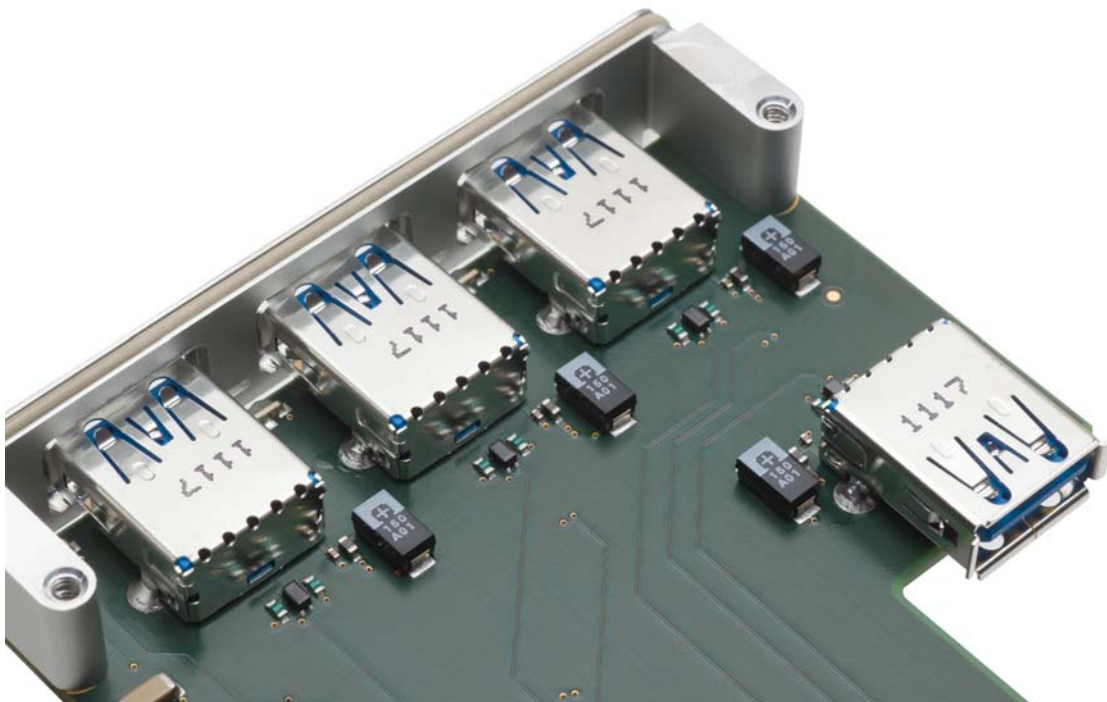

Installing and Replacing Components

Before You Begin

Warnings

The procedures in this chapter assume familiarity with the general terminology associated with industrial electronics and with safety practices and regulatory compliance required for using and modifying electronic equipment. Disconnect any telecommunication links, networks or procedures described in this chapter. Failure links before you open the system or perform or equipment damage. Some parts of the the power switch is in its off state.



the system from its power source and from modems before performing any of the to disconnect power, or telecommunication any procedures can result in personal injury system can continue to operate even though

Caution

Electrostatic discharge (ESD) can damage components. Perform the procedures described in this chapter only at an ESD workstation. If such a some ESD protection by wearing an metal part of the system chassis or board original ESD protected packaging. Retain the antistatic box) in case of returning the board to EKF for repair.



station is not available, you can provide antistatic wrist strap and attaching it to a front panel. Store the board only in its original packaging (antistatic bag and

Installing the Board Assembly

Warning

This procedure should be done only by qualified technical personnel. Disconnect the system from its power source before doing the procedures described here. Failure to disconnect power, or telecommunication links before you open the system or perform any procedures can result in personal injury or equipment damage.

Typically you will perform the following steps:

- Switch off the system, remove the AC power cord
- Attach your antistatic wrist strap to a metallic part of the system
- Remove the board packaging, be sure to touch the board only at the front panel
- Identify the related CompactPCI slot (peripheral slot for I/O boards, system slot for CPU boards, with the system slot typically most right or most left to the backplane)
- Insert card carefully (be sure not to damage components mounted on the bottom side of the board by scratching neighbored front panels)
- A card with onboard connectors requires attachment of associated cabling now
- Lock the ejector lever, fix screws at the front panel (top/bottom)
- Retain original packaging in case of return



Removing the Board Assembly

Warning

This procedure should be done only by qualified technical personnel. Disconnect the system from its power source before doing the procedures described here. Failure to disconnect power, or telecommunication links before you open the system or perform any procedures can result in personal injury or equipment damage.

Typically you will perform the following steps:

- Switch off the system, remove the AC power cord
- Attach your antistatic wrist strap to a metallic part of the system
- Identify the board, be sure to touch the board only at the front panel
- unfasten both front panel screws (top/bottom), unlock the ejector lever
- Remove any onboard cabling assembly
- Activate the ejector lever
- Remove the card carefully (be sure not to damage components mounted on the bottom side of the board by scratching neighbored front panels)
- Store board in the original packaging, do not touch any components, hold the board at the front panel only



Warning

Do not expose the card to fire. Battery cells and other components could explode and cause personal injury.



EMC Recommendations



In order to comply with the CE regulations for EMC, it is mandatory to observe the following rules:

- The chassis or rack including other boards in use must comply entirely with CE
- Close all board slots not in use with a blind front panel
- Front panels must be fastened by built-in screws
- Cover any unused front panel mounted connector with a shielding cap
- External communications cable assemblies must be shielded (shield connected only at one end of the cable)
- Use ferrite beads for cabling wherever appropriate
- Some connectors may require additional isolating parts

Technical Reference - Connectors

USB 3.0 Connectors

The DB4-EAGLE is equipped with three front bezel receptacles for USB 3.0 or USB 2.0 type A cable connectors (USB root hub). When connected to USB 2.0 compliant devices, only the classic 4 contacts (data pair, +5V and GND) are in use. USB 3.0 devices in addition communicate via the SuperSpeed differential transmit and receive signal pairs, available across another 5 contact pins.

USB 3.0 Receptacle		
<p>270.23.09.1 © EKF • ekf.com</p>	1	VBUS +5V 1.5Amax
	2	USB D-
	3	USB D+
	4	GND
	5	SS RX-
	6	SS RX+
	7	GND
	8	SS TX-
	9	SS TX+

Each connector provides +5V (VBUS) for powering external devices. Electronic switches limit the maximum output current of each individual USB connector to a safe level. The VBUS power has been derived from the XMC module VPWR rail. Dependent of the XMC carrier card, the VPWR voltage can be either +5V or +12V. The DB4-EAGLE features an on-board voltage comparator to detect the VPWR voltage actually present. If VPWR is +5V, it is directly used to feed the USB power switches. If VPWR is +12V, a DC-DC converter from +12V to +5V on the DB4-EAGLE will be enabled instead.

The maximum total VBUS output current is predominantly limited by the VPWR resources of the XMC carrier card. The electronic switches used on the DB4-EAGLE for USB VBUS are rated at >2A current limit typically, which is suitable even for applications where heavy capacitive loads are likely to be encountered. In total, if the voltage on the VPWR pins is +5V, this would imply a maximum current of >8A to be delivered from the XMC carrier card. When the VPWR voltage is +12V, the total permanently available USB VBUS current is limited mainly by the DB4-EAGLE on-board DC-DC regulator to ~4A maximum.

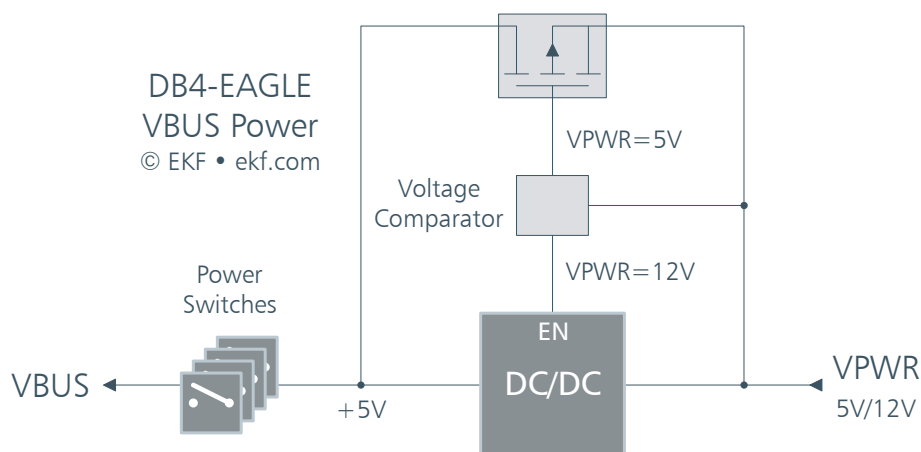

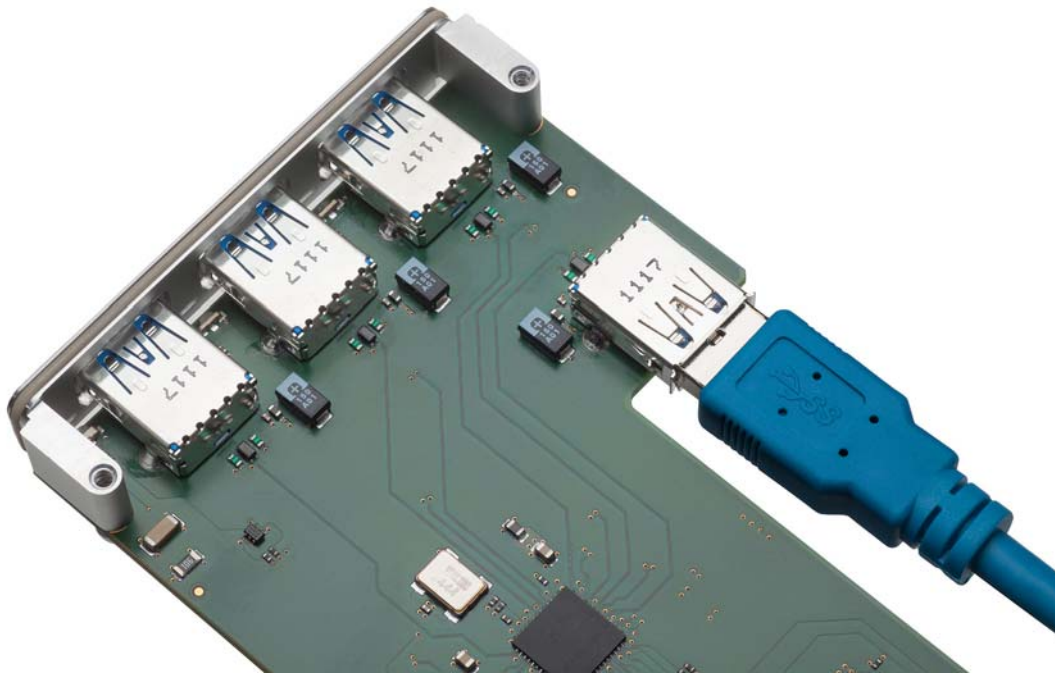

As an option, a 4th USB 3.0 connector may be populated on the DB4-EAGLE, for attachment of system internal devices. However, the connector height exceeds the XMC specification. In case of considering the additional on-board connector, the maximum component height on the carrier board must be checked first.

Vis-à-vis the optional 4th receptacle and associated USB 3.0 cable connector, a suitable landing zone would be required on the carrier board, with a maximum allowable component height of <2mm (the XMC specification allows for 4.7mm).

DB4-EAGLE on a CPCI Carrier Board - Sectional Drawing • © EKF • ekf.com

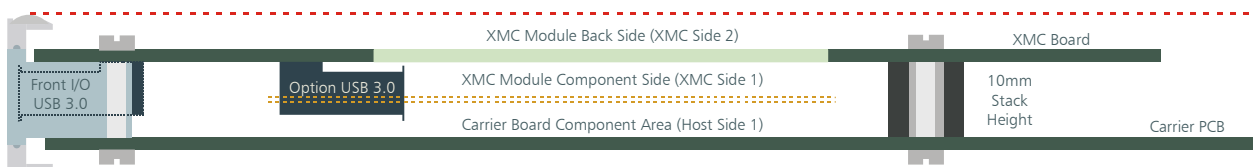

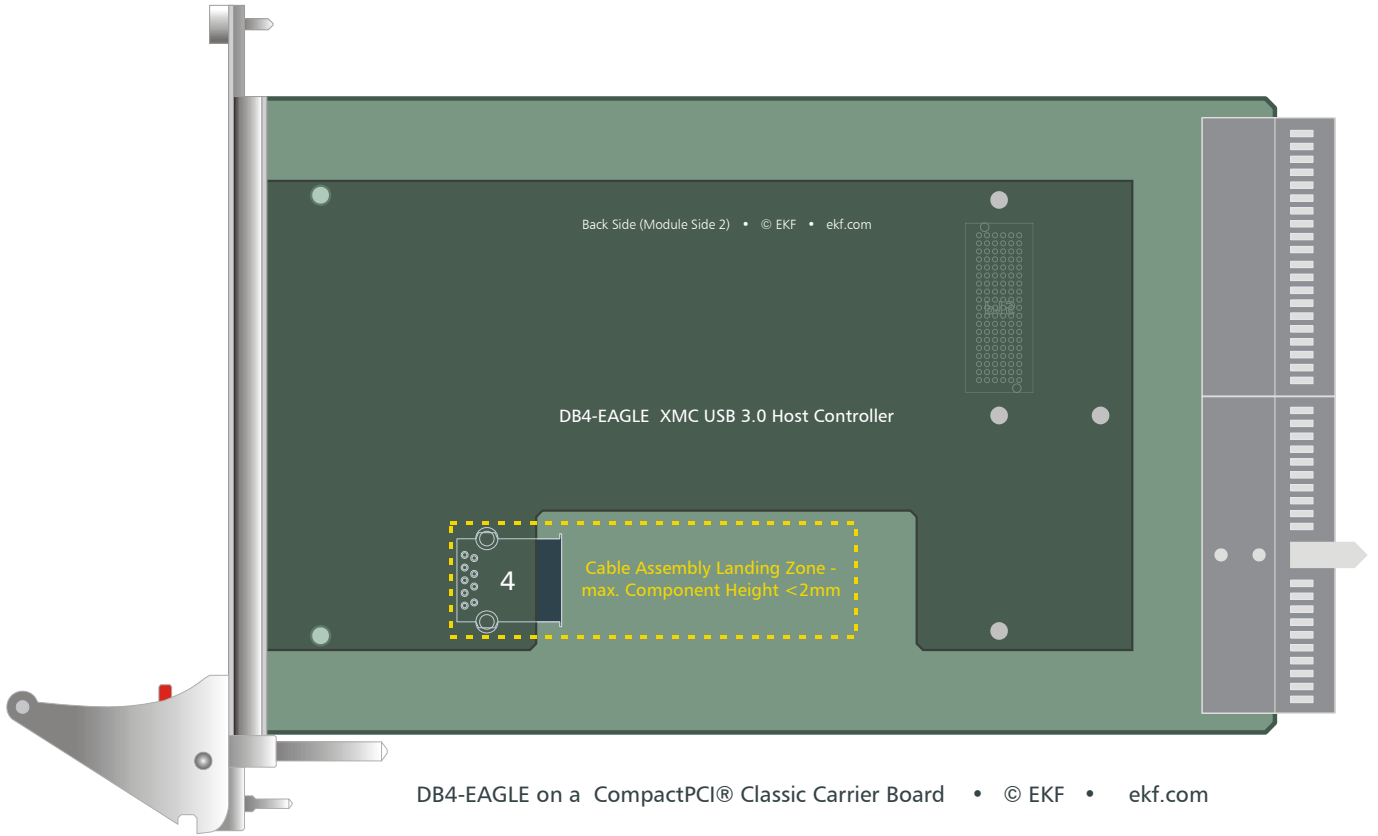

Check Landing Zone for Internal USB3 Cable Assembly



DB4-EAGLE on a SK2-SESSION CompactPCI® Serial Carrier Card

P15 Mezzanine Connector

The DB4-EAGLE is equipped with a high speed XMC mezzanine connector P15, mating with the host board J15 and establishing the data path (PCI Express®) and power link to the carrier. The pin assignment of P15/J15 is specified by VITA 42.3. The DB4-EAGLE is organized as single-lane single-link PCI Express® device.

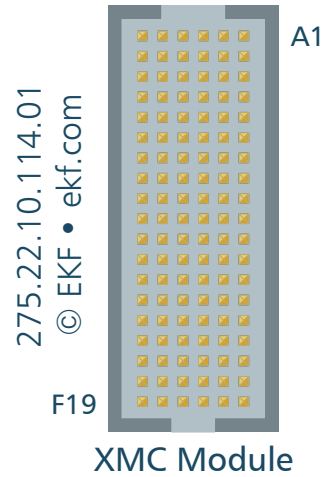

ANSI/VITA 42.3 defines a primary XMC connector P15, which is mandatory (for PCIe fabric), and a secondary XMC connector P16, which is optional (either fabric or user I/O). The DB4-EAGLE does not make use of P16. Suitable carrier cards are available from EKF, e.g. the SK2-SESSION CompactPCI® Serial XMC module carrier board.



SK2-SESSION • CompactPCI® Serial • XMC Module Carrier Board

XMC Connector P15 - PCIe Fabric • EKF Part No. 275.22.10.114.01						
	A	B	C	D	E	F
1	PETOP0	PETON0	+3.3V	<i>PETOP1</i>	<i>PETON1</i>	VPWR ²⁾
2	GND	GND	TRST# ¹⁾	GND	GND	MRSTI#
3	<i>PETOP2</i>	<i>PETON2</i>	+3.3V	<i>PETOP3</i>	<i>PETON3</i>	VPWR ²⁾
4	GND	GND	<i>TCK</i>	GND	GND	<i>MRSTO#</i>
5	<i>PETOP4</i>	<i>PETON4</i>	+3.3V	<i>PETOP5</i>	<i>PETON5</i>	VPWR ²⁾
6	GND	GND	<i>TMS</i>	GND	GND	+12V
7	<i>PETOP6</i>	<i>PETON6</i>	+3.3V	<i>PETOP7</i>	<i>PETON7</i>	VPWR ²⁾
8	GND	GND	<i>TDI</i>	GND	GND	-12V
9	<i>RFU</i>	<i>RFU</i>	<i>RFU</i>	<i>RFU</i>	<i>RFU</i>	VPWR ²⁾
10	GND	GND	<i>TDO</i>	GND	GND	GA0 ¹⁾
11	PEROP0	PERON0	<i>MBIST#</i>	<i>PEROP1</i>	<i>PERON1</i>	VPWR ²⁾
12	GND	GND	GA1 ¹⁾	GND	GND	MPRESENT#
13	<i>PEROP2</i>	<i>PERON2</i>	+3.3V_AUX	<i>PEROP3</i>	<i>PERON3</i>	VPWR ²⁾
14	GND	GND	GA2 ¹⁾	GND	GND	MSDA ¹⁾
15	<i>PEROP4</i>	<i>PERON4</i>	<i>RFU</i>	<i>PEROP5</i>	<i>PERON5</i>	VPWR ²⁾
16	GND	GND	MVMRO	GND	GND	MSCL ¹⁾
17	<i>PEROP6</i>	<i>PERON6</i>	<i>RFU</i>	<i>PEROP7</i>	<i>PERON7</i>	<i>RFU</i>
18	GND	GND	<i>RFU</i>	GND	GND	<i>RFU</i>
19	CLKP_XMC	CLKN_XMC	<i>RFU</i>	<i>WAKE#</i>	<i>ROOTO#</i>	<i>RFU</i>

pin positions printed italic/gray: reserved by specification / not connected

- 1) Serial EEPROM not populated by default (no IPMI)
- 2) VPWR is required for USB BusPower, +12V or +5V self-adjusting

Drivers

As of current (2012-04), some operating systems such as Ubuntu Linux provide already suitable drivers for the TUSB7340 quad port XHCI controller, unlike Windows® 7. Hence, Windows® drivers must be installed first before taking the advantage of SuperSpeed USB. Texas Instruments provides xHCI compliant Windows® drivers for download at

www.ti.com/product/tusb7340#toolssoftware

Schematics

Complete circuit diagrams for this product are available for customers on request. Signing of a non-disclosure agreement would be needed. Please contact sales@ekf.de for details.

EKF reserves the right to refuse distribution of confidential information material for any reason that EKF may consider substantial.

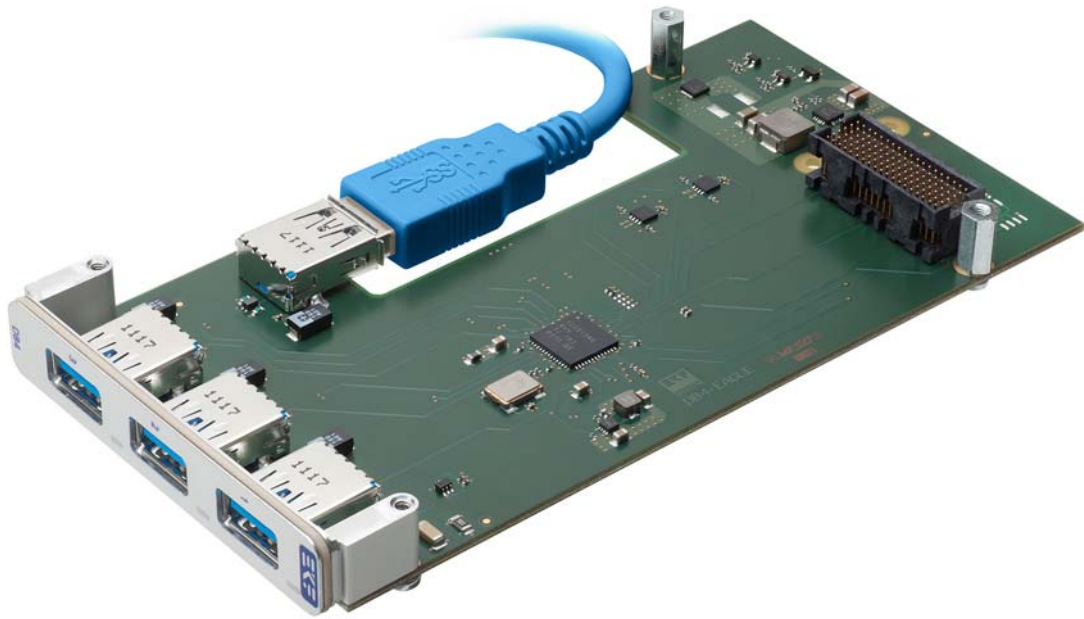

Internal Connector Option



DB4-EAGLE



SK2-SESSION CompactPCI® Serial XMC Module Carrier Card



SK2-SESSION w. DB4-EAGLE

Industrial Computers Made in Germany
boards. systems. solutions.

EKF Elektronik GmbH
Philipp-Reis-Str. 4
59065 Hamm
Germany



Phone +49 (0)2381/6890-0
Fax +49 (0)2381/6890-90
Internet www.ekf.com
E-Mail sales@ekf.com